

15, 20, 25, 30 and 40 Horsepower

Sullivan **Palatek®**

Rotary Screw Compressors

- ◆ **Direct Coupled**
- ◆ **C-Face Flange Mounted**
- ◆ **Advanced design
Increased Performance**
- ◆ **5 year warranty
Air end, motor, and coupling**



Proven performance with Exceptional Design

Standard Features

15, 20, 25, 30 and 40 Horsepower Compressors

- Compressor:** Oil flooded rotary screw, continuous duty, industrial air compressor Five Year air end warranty.
- Electric Motor:** 208, 230, or 460 volt 3 phase NEMA T-frame, C-face, One drip proof Squirrel cage induction type, Lincoln Motor five year warranty.
- Motor Starter:** 208, 230, or 460 volt full voltage starter with 120 volt controls, NEMA 1 enclosure, fused control transformer and three phase overloads.
- Coupling & Drive:** Compressor is flange mounted to motor for positive alignment and direct drive with a zero maintenance coupling.
- Air Intake Filter:** Over sized dry type with replacement element.
- Separator Tanks:** ASME coded tank with relief valve, minimum pressure/check valve, high efficiency replaceable oil separator element, fluid level sight indicator, and vented fill cap.
- Controls:** Full modulation, solenoid controlled for smooth pressure response and lowest no load power. Automatic start/stop or constant speed timed dual control.
- Instrumentation:** System and sump pressure gauges, hour meter, discharge temperature gauge, and oil filter and separator maintenance gauges.
- Protective Devices:** Three phase overload protection for motor, high temperature, and over pressure shutdown switches. An anti start switch in case of wrong rotation or insufficient internal pressure reduction at startup to protect motor from overload.
- Mounting:** Base mounted - No special foundation required
- Options:** Consult Harris Equipment for options or accessories not listed.

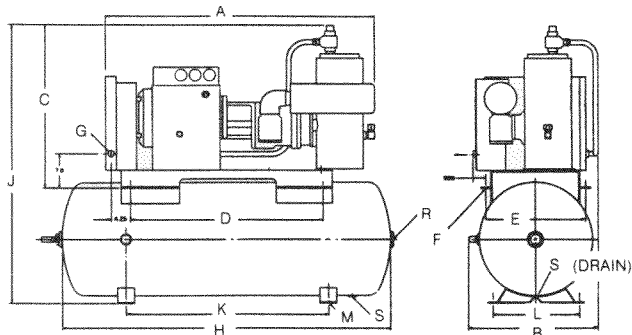

Crated dimensions L-84", W-45", H-60" (Tank MTD 74")
 Add 100 pounds for crating - all dimensions in inches
 specifications subject to change without notice



Sold and serviced by
Harris Equipment Corporation
2010 North Ruby Street
Melrose Park, IL 60160
Phone 708-343-0866
FAX 708-343-0995

BASE MTD	15D	20D	25D	25D4	30D7	40D
A	56"	56"	59"	59"	58"	60"
B	29"	29"	29"	29"	30"	34"
C	34"	38"	35"	38"	35"	39"
D	40"	40"	40"	40"	40"	40"
E	21.38"	21.38"	21.38"	21.38"	21.38"	21.38"
F	.75"	.75"	.75"	.75"	.75"	.75"
G	1" NPT	1" NPT	1" NPT	1" NPT	1" NPT	1" NPT
MOTOR HP	15	20	25	25	30	40
SUMP CAP	3 GAL	3 GAL	3 GAL	3 GAL	3 GAL	3.5 GAL
WEIGHT	700	800	900	950	950	1000
TANK MTD	120 G	120 G	120 G	120 G	120 G	200 G
H	69"	69"	69"	69"	72"	72"
J	59"	63"	60"	63"	68"	70"
K	42"	42"	42"	42"	42"	42"
L	18.5"	18.5"	18.5"	18.5"	24"	24"
M	.9	.9	.9	.9	.9	.9
R	2" NPT	2" NPT	2" NPT	2" NPT	2" NPT	2" NPT
S	.5 NPT	.5 NPT	.5 NPT	.5 NPT	.5 NPT	.5 NPT
TANK DIA	24	24	24	24	24	30
WEIGHT	1050#	1150#	1250#	1300#	1350#	1400#