

40, 50, and 60 Horsepower

Sullivan **Palatek®**

Rotary Screw Compressors

- ◆ **Direct Coupled**
- ◆ **C-Face Flange Mounted**
- ◆ **Advanced design
Increased Performance**
- ◆ **5 year warranty
Air end, motor, and coupling**



Proven performance with Exceptional Design

Standard Features

40, 50 and 60 Horsepower Compressors

- Compressor:** Oil flooded rotary screw, continuous duty, industrial air compressor Five Year air end warranty.
- Electric Motor:** 208, 230, or 460 volt 3 phase NEMA T-frame, C-face, One drip proof Squirrel cage induction type, Lincoln Motor five year warranty.
- Motor Starter:** 208, 230, or 460 volt full voltage starter with 120 volt controls, NEMA 1 enclosure, fused control transformer and three phase overloads.
- Coupling & Drive:** Compressor is flange mounted to motor for positive alignment and direct drive with a zero maintenance coupling.
- Air Intake Filter:** Over sized dry type with replacement element.
- Separator Tanks:** ASME coded tank with relief valve, minimum pressure/check valve, high efficiency replaceable oil separator element, fluid level sight indicator, and vented fill cap.
- Controls:** Full modulation, solenoid controlled for smooth pressure response and lowest no load power. Automatic start/stop or constant speed timed dual control.
- Instrumentation:** System and sump pressure gauges, hour meter, discharge temperature gauge, and oil filter and separator maintenance gauges.
- Protective Devices:** Three phase overload protection for motor, high temperature, and over pressure shutdown switches. An anti start switch in case of wrong rotation or insufficient internal pressure reduction at startup to protect motor from overload.
- Mounting:** Base mounted - No special foundation required
- Options:** Consult Harris Equipment for options or accessories not listed.
Specifications subject to change without notification.

MODEL	40UD	50UD	60UD
DRIVE MOTOR HP.	40	50	60
FAN MOTOR HP.	1	1	1.5
SUMP CAPACITY GAL	3.5	3.5	3.5
DISCHARGE IN.	1.25	1.25	1.25
LENGTH IN.	66	66	66
LENGTH W/ENCL IN.	79	79	79
WIDTH IN.	34	34	34
HEIGHT IN.	49	49	49
WEIGHT LBS.	1300	1400	1700
WITH ENCL LBS	1600	1700	2000

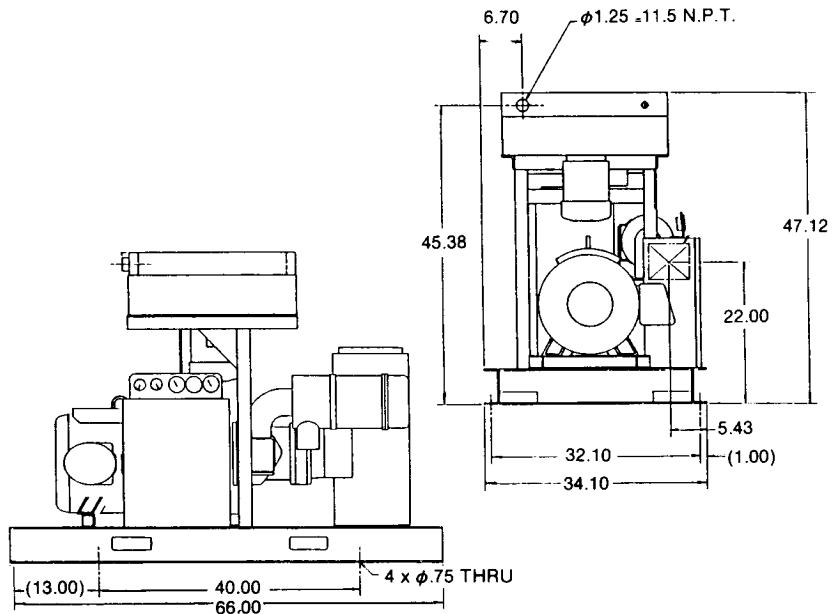

Crated dimensions L-84", W-45", and H-60"
All weight in pounds and dimensions in inches
Add 100 pounds for crating.



**Sold and serviced by
Harris Equipment Corporation
2010 North Ruby Street
Melrose Park, IL 60160
Phone 708-343-0866
FAX 708-343-0995**