

# **Sullivan Palatek®**

## Rotary Screw Compressors

- ◆ **Direct Coupled**
- ◆ **C-Face Flange Mounted**
- ◆ **Advanced design  
Increased Performance**
- ◆ **5 year warranty  
Air end, motor, and coupling**



Proven performance with Exceptional Design

**Standard Features**

**75 and 100 Horsepower Compressors**

- Compressor:** Oil flooded rotary screw, continuous duty, industrial air compressor Five Year air end warranty.
- Electric Motor:** 208, 230, or 460 volt 3 phase NEMA T-frame, C-face, One drip proof Squirrel cage induction type, Lincoln Motor five year warranty.
- Motor Starter:** 208, 230, or 460 volt full voltage starter with 120 volt controls, NEMA 1 enclosure, fused control transformer and three phase overloads.
- Coupling & Drive:** Compressor is flange mounted to motor for positive alignment and direct drive with a zero maintenance coupling.
- Air Intake Filter:** Over sized dry type with replacement element.
- Separator Tanks:** ASME coded tank with relief valve, minimum pressure/check valve, high efficiency replaceable oil separator element, fluid level sight indicator, and vented fill cap.
- Controls:** Full modulation, solenoid controlled for smooth pressure response and lowest no load power. Automatic start/stop or constant speed timed dual control.
- Instrumentation:** System and sump pressure gauges, hour meter, discharge temperature gauge, and oil filter and separator maintenance gauges.
- Protective Devices:** Three phase overload protection for motor, high temperature, and over pressure shutdown switches. An anti start switch in case of wrong rotation or insufficient internal pressure reduction at startup to protect motor from overload.
- Mounting:** Base mounted - No special foundation required
- Options:** Consult Harris Equipment for options or accessories not listed.

Specifications subject to change without notification.

MODEL	75DG	100DG
Drive Motor HP.	75	100
Fan Motor HP.	2	3
Sump Capacity GAL.	10	10
Discharge IN.	1.5	2
Length IN. (open)	80	80
Length IN. (enclosed)	80	80
Width IN.	45	45
Height IN. (open)	60	60
Height IN. (enclosed)	65	65
Weight lbs (open)	2900	3200
Weight lbs (enclosed)	3400	3700

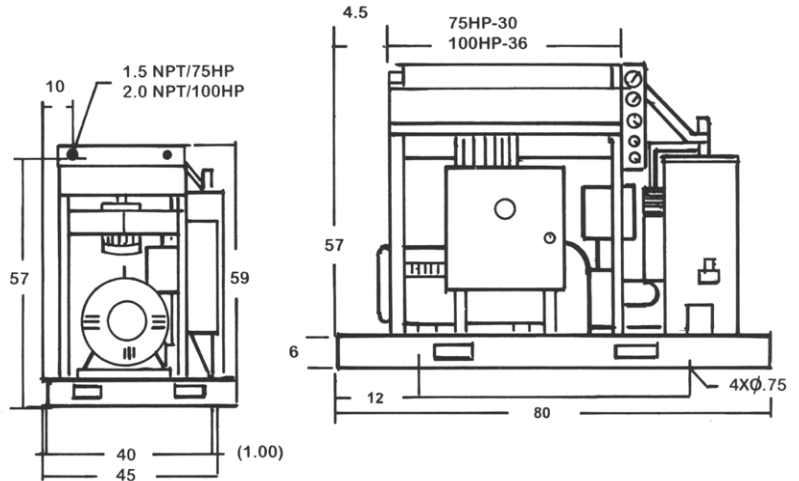

Crated dimensions L-84", W-45", and H-64"  
 All weight in pounds and dimensions in inches  
 Add 100 pounds for crating.



**Sold and serviced by  
 Harris Equipment Corporation  
 2010 North Ruby Street  
 Melrose Park, IL 60160  
 Phone 708-343-0866  
 FAX 708-343-0995**